



1/2 ton 1100 lb 110V Electric Wire Rope Hoist 38 ft. H1 Duty

Key features

- Load Capacity: 1/2 ton (1100 lbs), suitable for moderate lifting tasks.
- Voltage: 110V, designed for standard power sources.
- Lifting Height: 38 ft, providing significant vertical movement capability.
- 1 Year Warranty, Customer Support and Service in the USA

Electric Wire Rope Hoist Description

Our magnificent **Prowinch 1/2 ton Electric Wire Rope Hoist** is the ideal product for light loads and small shop use. Exceeding expectations in performance and durability this is one of the most technologically advanced electric wire rope hoist in the industry. With the convenience of low headroom and a wired remote this unit can be easily incorporated into your shop or home.

Prowinch Electric Wire Rope Hoists

All of our electric wire rope hoists are created with the goal of offering the best price-performance ratio. Key components such as lifespan factors are constantly tested and improved in order to offer the best product for the price.

Key Components

All internal components have been upgraded to meet the highest quality standards. All testing is performed in the US before shipping to ensure that every unit meets the corresponding standard.

Duty Classification

Duty classification is a key factor when choosing the right unit. This H1 electric wire rope hoist is suitable for infrequent handling, installing and servicing heavy equipment, and idling for long periods between use. For uniformly distributed work periods, the hoist has a 12.5% max. operational time per hour and can handle up to 75 starts per hour. When being used for infrequent work periods, the hoist can be operated for 15 minutes from a cold start with up to 100 starts per hour. Operational time ratings are calculated at a 65% load factor, as per ASME Standards.

Control System

This electric wire rope hoist comes standard with an industrial wired remote control, which is waterproof, shockproof, and with optional wireless it can be operated from 100 feet away. It also features a safety key and emergency stop button.

Braking System

The electromagnetic brake system is tested at 125% of the hoist capacity and is designed to automatically engage immediately upon any loss of power.

Technical Specifications

Rated Load Capacity	1100 lb @ 2 lines 550 lb @ 1 line	IEC Motor Protection	IP40
Standard Lifting Height	38ft @ 1 line / 19ft @ 2 line	Control	Pendant Control
Speed (f/m) / min	33 ft/10m @1line 16ft/5m @2line	Control Voltage	110 V
Number of Speeds	1 Speed	Emergency Stop	YES
Voltage	1 Phase 110~120V 60Hz	Wire Rope	ø11/64 in ø4.3 mm
Duty Class	H1/M2/1Cm/Class A	Humidity	<85%
Motor Type (68)	Squirrel Cage Induction Motor	Temperature	-4°~104° F / -20°~40° C
Motor Power (6)	1450W	Noise Level	71 dB
Motor AMP	8.5 AMP	Standards Compliance	Intertek 4006091 , CAN/CSA C22.2 , EN14492-2 , EN60204-32
Motor Brake	YES	Warranty	1 Year
Insulation Grade	B		

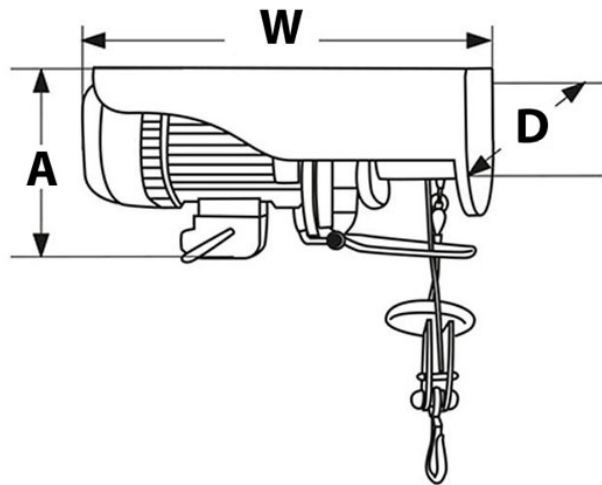

Unit Weight & Dimensions

H Minimum Headroom	10.8 in / 275 mm	Package 1 Net Weight	37 lbs / 17 Kg
W Width	13.0 in / 330 mm	Package 1 Width	8 in / 20.32 cm
D Depth	5.1 in / 130 mm	Package 1 Gross Weight	39 lbs / 18 Kg
Total Unit Weight	37 lbs / 17 Kg	Package 1 Height	11 in / 27.94 cm
		Package 1 Length	17 in / 43.18 cm

Packaging Weight & Dimensions