

## 1/2 ton 1100 lb 110V Electric Wire Rope Hoist 38 ft. H1 Duty Wireless

### Key features

- Load Capacity: 1/2 ton (1100 lbs), ideal for lighter lifting tasks.
- Voltage: 110V, suitable for standard electrical setups.
- Lifting Height: 38 ft, providing ample vertical reach.
- 1 Year Warranty, Customer Support and Service in the USA



### Electric Wire Rope Hoist Description

Our magnificent **Prowinch 1/2 ton Electric Wire Rope Hoist** is the ideal product for light loads and small shop use. Exceeding expectations in performance and durability this is one of the most technologically advanced electric wire rope hoist in the industry. With the convenience of low headroom and a wireless remote this unit can be easily incorporated into your shop or home.

### Prowinch Electric Wire Rope Hoists

All of our electric wire rope hoists are created with the goal of offering the best price-performance ratio. Key components such as lifespan factors are constantly tested and improved in order to offer the best product for the price.

### Key Components

All internal components have been upgraded to meet the highest quality standards. All testing is performed in the US before shipping to ensure that every unit meets the corresponding standard.

### Duty Classification

Duty classification is a key factor when choosing the right unit. This H1 electric wire rope hoist is suitable for infrequent handling, installing and servicing heavy equipment, and idling for long periods between use. For uniformly distributed work periods, the hoist has a 12.5% max. operational time per hour and can handle up to 75 starts per hour. When being used for infrequent work periods, the hoist can be operated for 15 minutes from a cold start with up to 100 starts per hour. Operational time ratings are calculated at a 65% load factor, as per ASME Standards.

### Control System

This electric wire rope hoist comes standard with an industrial wireless remote control, which is waterproof, shockproof, and can be operated from 100 feet away. It also features a safety key and emergency stop button.

### Braking System

The electromagnetic brake system is tested at 125% of the hoist capacity and is designed to automatically engage immediately upon any loss of power.

## Technical Specifications

<b>Rated Load Capacity</b>	1100 lb @ 2 lines   550 lb @ 1 line	<b>Insulation Grade</b>	B
<b>Standard Lifting Height</b>	38ft @ 1 line / 19ft @ 2 line	<b>IEC Motor Protection</b>	IP40
<b>Speed (f/m) / min</b>	33 ft/10m @1line   16ft/5m @2line	<b>Control</b>	Wireless F21 Remote Control
<b>Number of Speeds</b>	1 Speed	<b>Control Voltage</b>	2 x AA 1,5v
<b>Voltage</b>	1 Phase 110~120V 60Hz	<b>Emergency Stop</b>	YES
<b>FCC ID</b>	OFNF21	<b>Wire Rope</b>	ø3/16 in   ø4.3 mm
<b>Duty Class</b>	H1/M2/1Cm/Class A	<b>Humidity</b>	<85%
<b>Motor Type (68)</b>	Squirrel Cage Induction Motor	<b>Temperature</b>	-4°~104° F / -20°~40° C
<b>Motor Power (6)</b>	1000W	<b>Noise Level</b>	71 dB
<b>Motor AMP</b>	8.5 AMP	<b>Standards Compliance</b>	Intertek 4006091 , EN 55014-1:2017, EN 55014-2:2015, EN IEC 61000-3-2:2019, EN 61000-3-3:2013
<b>Motor Brake</b>	YES	<b>Warranty</b>	1 Year

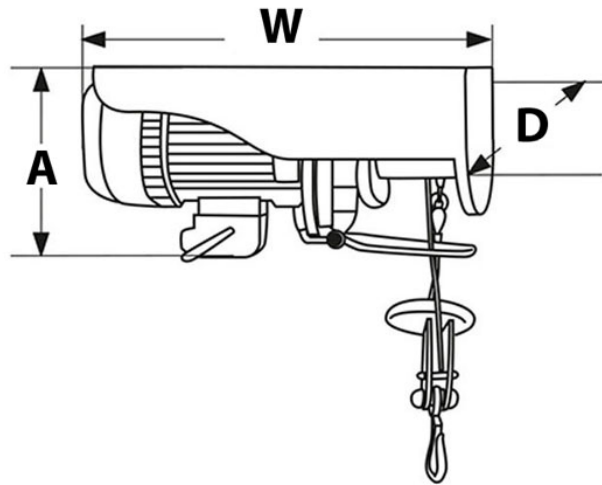

## Unit Weight & Dimensions

<b>H Minimum Headroom</b>	10.8 in / 275 mm	<b>Package 1 Net Weight</b>	37 lbs / 17 Kg
<b>W Width</b>	13.0 in / 330 mm	<b>Package 1 Width</b>	8 in / 20.32 cm
<b>D Depth</b>	5.1 in / 130 mm	<b>Package 1 Gross Weight</b>	39 lbs / 18 Kg
<b>Total Unit Weight</b>	37 lbs / 17 Kg	<b>Package 1 Height</b>	11 in / 27.94 cm
		<b>Package 1 Length</b>	17 in / 43.18 cm

## Packaging Weight & Dimensions